

MOVIA 2-AXIS SCAN HEAD

COMPACT SCAN HEAD FOR INDUSTRIAL MARKING, CODING, AND MICROMACHINING SYSTEMS

Novanta develops photonics solutions through our globally recognized brands— ARGES, Cambridge Technology, Laser Quantum and Synrad— specializing in cutting-edge components and sub-systems for laser-based diagnostic, analytical, micromachining and fine material processing applications. Powerful lasers, coupled with advanced beam steering and intelligent sub-systems incorporating software and controls, deliver extreme precision and performance, tailored to our customers' demanding applications.

NEXT GENERATION OF SCAN HEADS

Cambridge Technology's next generation of 2-axis scan heads feature a compact, industrial design with improved throughput and uptime. Designed for easy system integration due to its compact size and industry-standard interfaces, MOVIA is well-suited for a variety of marking and coding processes. Specifically those that require high throughput and consistent, reliable quality when repeating marks. MOVIA is ideal for non-contact marking of logos, alpha-numeric codes, barcodes, graphics, expiration dates, and many other applications. It has passed numerous extreme condition tests to ensure reliability and safety and is IP50 rated.



Marking & Coding



Micromachining

IMPROVED PERFORMANCE

- Easily integrated into existing systems due to its small size and support of industry standard interface and connectors
- High quality character marking resulting from improved electronics and tuning design
- Tested to perform under extreme conditions to ensure high quality and reliability
- Tested with other Novanta products including Synrad's CO₂ lasers and Cambridge Technology's ScanMaster Controller

EXAMPLE OF TYPICAL CHARACTER MARKING¹

ABCDEFGHIJKLMNOPQRSTUVWXYZ
abcdefghijklmnopqrstuvwxyz
0123456789

CPS 800

ABCDEFGHIJKLMNOPQRSTUVWXYZ
abcdefghijklmnopqrstuvwxyz
0123456789

CPS 1000

References:

1. Examples shown using 160 mm F-Theta lens and single stroke 1 mm characters, SIMPLEX font. Used with ScanMaster Controller. More examples and full parameter set available upon request.

MOVIA 2-AXIS SCAN HEAD

Specifications	10 mm
Mirror Aperture Size	10 mm
Tune Type	Vector tune
Scan Angle	±20°
Beam Displacement	12.05 mm
Step Response Time 1% of Full Scale ¹	<210 μs
Typical Marking Speed ²	3 m/s
Typical Positioning Speed ²	16 m/s
Repeatability	<3.5 μrad
Tracking Error	<130 μs
Linearity	> 99.9% over 20°
Wavelength Options ³ Max Power	CO ₂ : 9.2 - 10.6 μm 125 W Fiber: 1040 - 1090 nm 125 W Green: 532 nm check with factory UV: 353 - 357 nm check with factory
Gain Error	<5 mrad
Zero Offset	<5 mrad
Long Term Offset Drift ⁴	<100 μrad
Long Term Scale Drift ⁴	<150 ppm
Temperature Offset Drift	<20 μrad/°C
Temperature Scale Drift	<20 ppm/°C
Command Resolution	16 bit
Communication Interface	XY2 - 100
IP Rating	IP50
Power Requirements	±15V, 3A RMS
Operating Temperature	15 °C - 35 °C
Weight (approximate)	1.5 kg
Dimensions (L x W x H)	114 mm x 94 mm x 86 mm

Notes:

All angles are in optical degrees, unless otherwise noted. All specifications are subject to change without notice.

References:

1. Settling to within 1% of position. 2. With 160mm F-Theta lens. 3. Supports HeNe laser band. 4. During 24 hours of operation after 30 minutes of warm up, per axis.

MOVIA 2-AXIS SCAN HEAD

10 MM

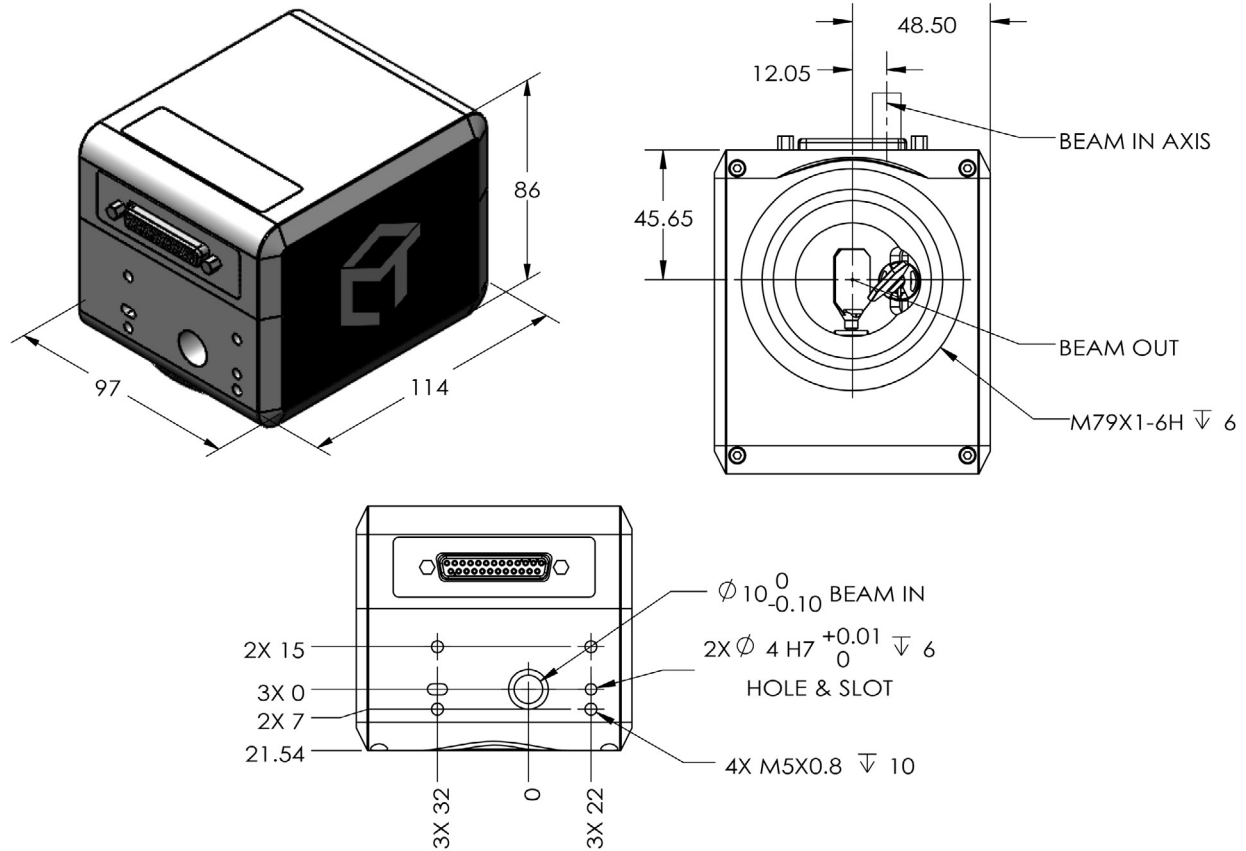

Notes:

All angles are in optical degrees, unless otherwise noted. Dimensions are in millimeters. All specifications are subject to change without notice.

Contact factory for accessories inquiries.



电话: 0755-84870203
 网址: www.highlightoptics.com



www.NovantaPhotonics.com